

# BCI-Brake

24 V DC



- The spring applied brakes are single-disc brakes with two friction surfaces.
- The braking torque is generated by compression springs.
- The brake is released electromagnetically. Braking occurs when the supply voltage is switched off.
- Protection class IP 00.
- Insulation class F.

## Nominal Data

Type		BFK 457-01	BFK 457-02	BFK 457-03
Nominal power*	W	5.0	6.6	9.0
Nominal torque of brake**	Nm	0.12	0.25	0.50
Engagement time	ms	11.0	8.0	12.5
Disengagement time	ms	17	17	18
Maximum speed	min <sup>-1</sup>	5000	5000	5000
Weight	kg	0.20	0.25	0.40
d	mm	37.0	47.0	56.0
L1	mm	31.3	31.0	31.8
L2	mm	35.3	37.0	38.0
Motor Series***		BCI 42	BCI 52	BCI 63

\* Nominal power of the coil at 24 V DC and 20° C..

\*\* Nominal torque of brake, referring to a speed of 100 rpm.

\*\*\* Brake for motors and worm gear motors available on request.  
Available at short notice for all other designs.

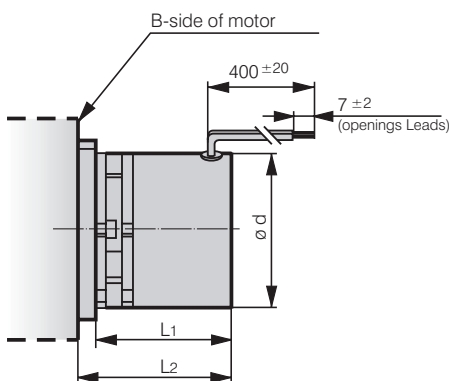

### Note:

Only one accessory component (brake or sensor) can be mounted onto a motor at a time.